

SEBASTIAN PRINTMAKING EQUIPMENT

SEBASTIAN PAPER BATH SINK

MODEL: SPBS-503634-RD

SEBASTIAN 16 GA. TYPE 304 STAINLESS STEEL SINK WITH BACKSPLASH, #4 FINISH, 16 GA. REINFORCED STAINLESS STEEL BASE WITH 2x2x3/16" UNDER-SINK ANGLE SUPPORTS, 1/2" THICK SOUND DEADENING MATERIAL AND SINK LEVELING FLOOR PADS
OUTSIDE DIMENSIONS: 50"x36"x34" INSIDE: 47"x32"x5" DEEP
FOR PAPER TO SIZE: 30"x40."

1-1/2" ϕ RECESSED DRAIN w/3" HIGH REMOVABLE STANDPIPE (ALLOWS FOR FULL USE OF THE SINK WITH 30"x40" PAPER)

WATER SAVER #L-2212VB-BH MIXING FAUCET WITH VACUUM BREAKER & HOSE ADAPTER

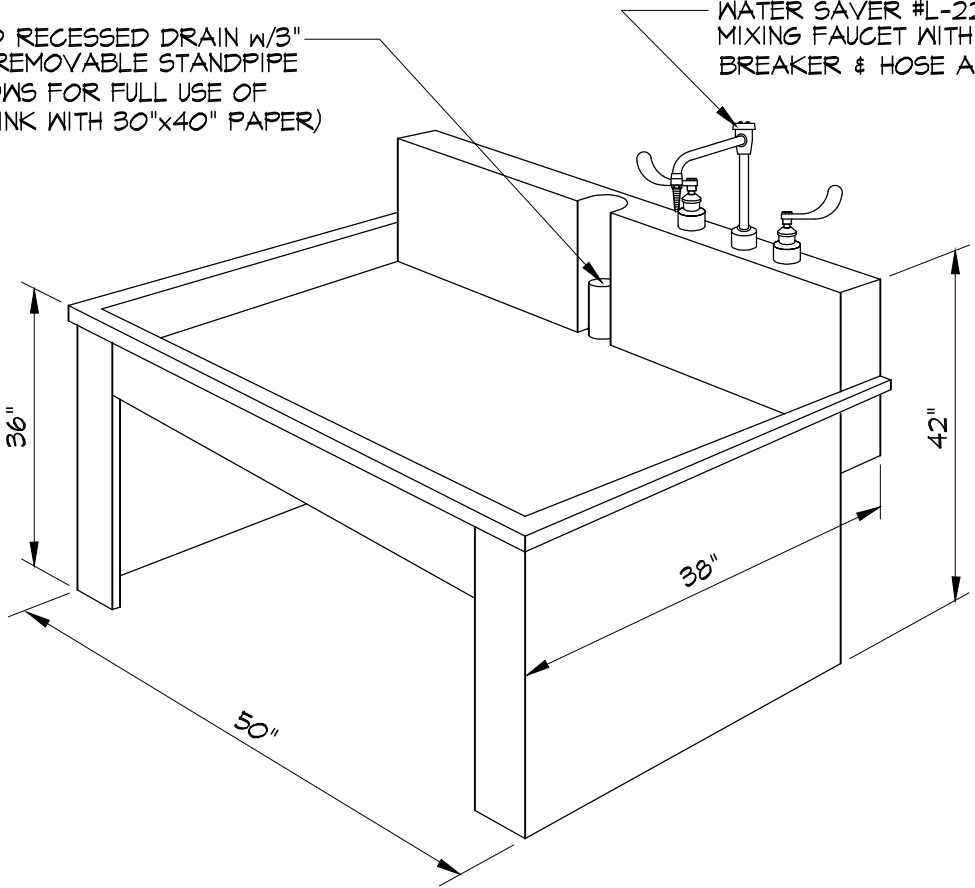

NOTE: THIS SINK DOES NOT COMPLY WITH ADA GUIDELINES (THE FAUCET REACH IS BEYOND 24")

12-1-2014



SEBASTIAN DARKROOM PRODUCTS™

DIVISION OF CALIFORNIA STAINLESS MFG., INC.

UNIQUE, INNOVATIVE & ENGINEERED TO WORK

TOLL FREE (888) 712-7035 FAX (805) 484-1030

calstainless@aol.com www.sebastiandarkroomprod.com